



**M** A C U L A



# Contents

---

Safety Information	Page	4 - 5
Introduction and unpacking		6
<hr/> <b>HARDWARE</b> <hr/>		
Overview		7
Macula Encoder		8
System Hook Up		9
Left handle Bar		10
Right Handle Bar		11
<hr/> <b>SOFTWARE</b> <hr/>		
System		12
Fixtures		13 - 16
Presets		17
Camera		18
Clean View Operator		19
Beam Settings		20
Color1 Settings		21
Color2 Settings		22
Position Settings		23
Fixture Control Settings		24
Trouble Shooting		25



# Safety Information

---



## WARNING!

Read the safety precautions in this section before installing, powering, operating or servicing this product.



**Warning!**  
Safety hazard.  
Risk of severe injury or death.



**Warning!**  
Fire hazard.



**Warning!**  
Refer to manual before installing, powering or servicing.



**Warning!**  
Hazardous voltage. Risk of severe or lethal electric shock.

---

The following symbols are used to identify important safety information on the product and in this document



**Warning!** Read this user manual before installing and operating the Macula System

**Warning!** The Macula System is designed to integrate with other devices in DMX, SaCN or Artnet installations.

Follow the safety precautions given not only in this user manual but also in the manuals of all the devices you connect to it. Observe all warnings given in the manuals and printed on devices. Install and operate devices only as described in the manuals and only in accordance with local laws and regulations. Keep this manual for future reference.



**Warning!** The Macula System is not for household use. It presents risks of severe injury or death due to fire and burn hazards, electric shock and falls. It must be installed by qualified technicians only.

**Warning!** There are no user-serviceable parts inside the Macula System. Refer any operation not described in this manual to LC Innovation or its authorized service agents.

If you have any questions about how to operate the Macula System safely, please contact your Macula supplier or contact by mail [info@lcinnovation.com](mailto:info@lcinnovation.com)



#### PROTECTION FROM ELECTRIC SHOCK

- The Macula System is based on an external power supply converting from 90V - 230V AC to DC 12V the power supply are CE marked and all currents running inside the system are converted DC12V to the appropriate voltage needed in the system.
- Check and respect the directions given by the user manuals of all the devices that you intend to connect to the Macula System. Particularly the instructions, warnings and limits that apply to:
  - System Layout
  - Connections to other devices
  - Specified cables
  - Maximum cable length
  - Maximum number of devices that can be connected
  - Grounding of electrical appliances
- Provide a means to locking out AC mains power that allows power to be shut down and made impossible to



- reapply, even accidentally, during service and when it is not in use.
- Shut down power to the installation during service and when it is not in use.
- Ensure that the Macula System is electrically connected to ground (earth).
- Connect the Macula System PSU to AC mains power at 100-240 V (nominal), 50/60 Hz only.
- Use only a source of AC mains power that complies with local building and electrical codes and has both over-load and ground-fault (earth-fault) protection.
- Use only a power input cable that has 12 AWG or 4 mm<sup>2</sup> minimum conductor size and an outer cable diameter of 10 - 15 mm (0.4 - 0.6 in.). Power cable must be hard usage type (SJT or equivalent) and heat-resistant to 90° C (194° F) minimum. In the EU the cable must be HAR type.
- Use only the cables specified by LC Innovation for the devices concerned to interconnect them. If the specified cables are not long enough for an intended cable run, consult LC Innovation for assistance in finding or creating a safe alternative cable
- Before applying power to the installation, check that all power distribution equipment and cables are in perfect condition and rated for the current requirements of all connected devices.
- Isolate the installation from power immediately if the product, power cable or power plug are in any way damaged, defective or wet, or if they show signs of overheating.
- Do not expose the Macula System to rain or moisture.



#### PROTECTION FROM BURNS AND FIRE

- Do not attempt to bypass fuses. Replace defective fuses with fuses of the same type and rating only.
- Provide free airflow and a minimum clearance of 100 mm (4 in.) around fans and air vents.
- Do not operate the Macula System if the ambient temperature (Ta) exceeds 45° C (113° F).
- Do not modify the Macula System in any way not described in this manual or install other than genuine LC Innovation parts. Use only accessories approved by LC Innovation.



#### PROTECTION FROM INJURY

- Cameras mounted on moving heads has to be secured with safety so in the event of separation from the movinghead it can not fall.
- Installing cameras to the moving head shall either be done while it can be accessed from the ground or from a platform if it is in the air.

check that all hardware and components are securely in place and that all installation and rigging hardware used is securely fastened.

# Introduction

---

Thank you for selecting Macula. Macula is the only open System open to any fixture of your choice. The Macula system can be used as a direct system or as multiple fixture setup. It is the first system to enable the synergy between Follow Operator and Light Designer shifting between functions used by Light Designer or leaving more controls to the Operator.

The Macula System still provide an intuitive approach to a very complexed system.

Development of fixture profiles can be adressed to [info@lcinnovation.com](mailto:info@lcinnovation.com)

LC Innovation hope that you will enjoy the functionalities of the system.

WORKFLOW

# Unpacking

---

The following items are included with the Macula System

- Tripod
- 1 pcs touch screen 17"
- 1 pcs Macula System Control unit and Encoder Head
- 1 pcs 12V PSU, Male True1 Neutric -> 4 pin XLR Neutric Female
- 1 pcs left handle bar
- 1 pcs right handle bar
- 1 pcs Camera box with 16mm Spigot (superclamp/safetywire not included)

Cable package

- 1 pcs HDMI
- 12V 4P XLR cable
- 2 pcs 7p XLR Neutric cables
- 1 pcs USB 2.0 cable
- 1 pcs 2m RJ45 CAT5 Camera



All External Cables to communicate with network system are not included in the package.

The complete package of the Macula System contains cables to setup and test signals in and out of the system, RJ45 CAT5 min. can run upto 90m without any additional.



# Overview

## Macula Control Unit - Rear Box - Connector Panel Front

The Control unit are attached to the Macula Encoder Unit diagram.

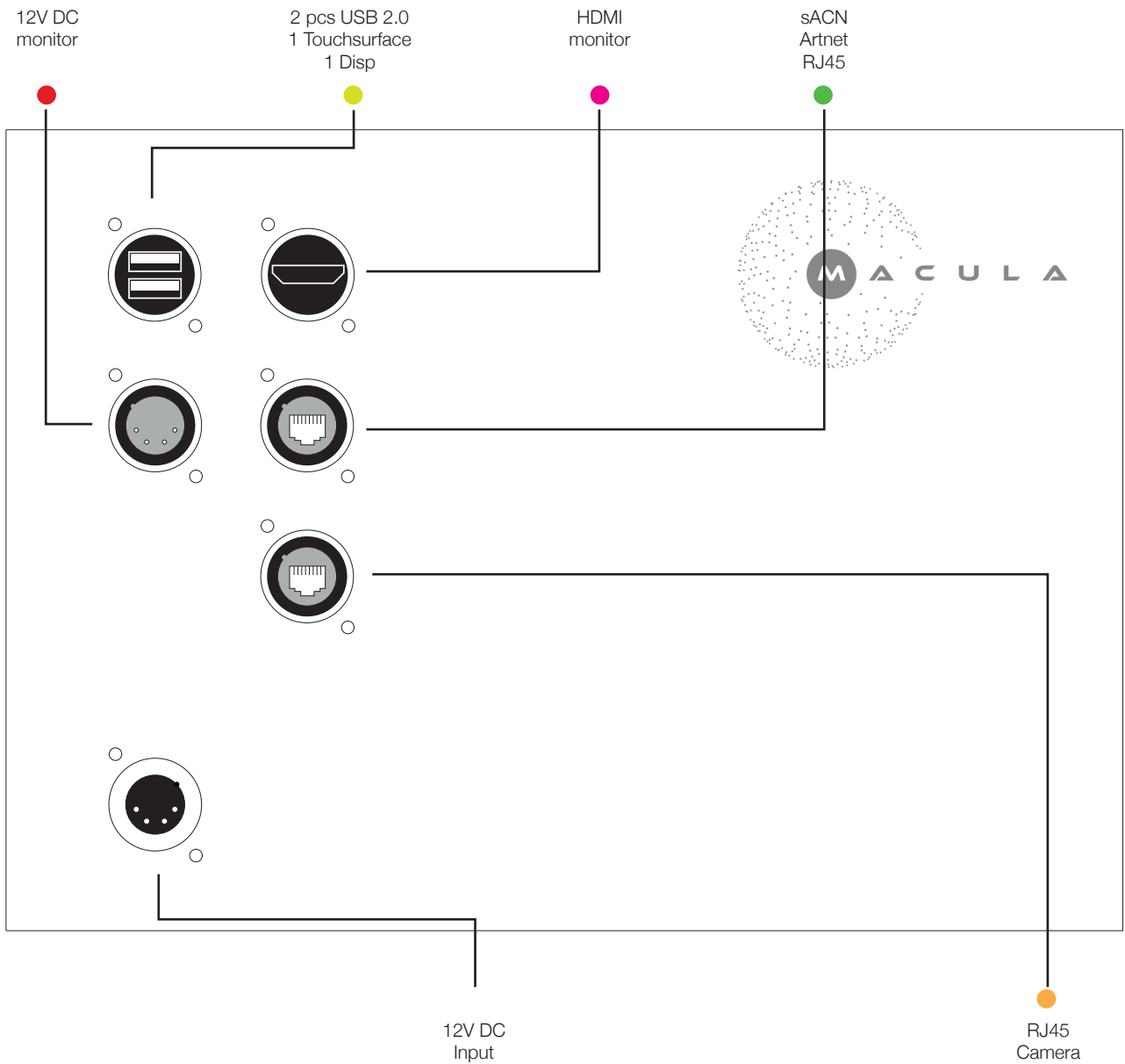

# Macula Encoder

## Macula Control Unit - Rear Box - Connector Panel Back

The Control unit are attached to the Macula Encoder Unit diagram.

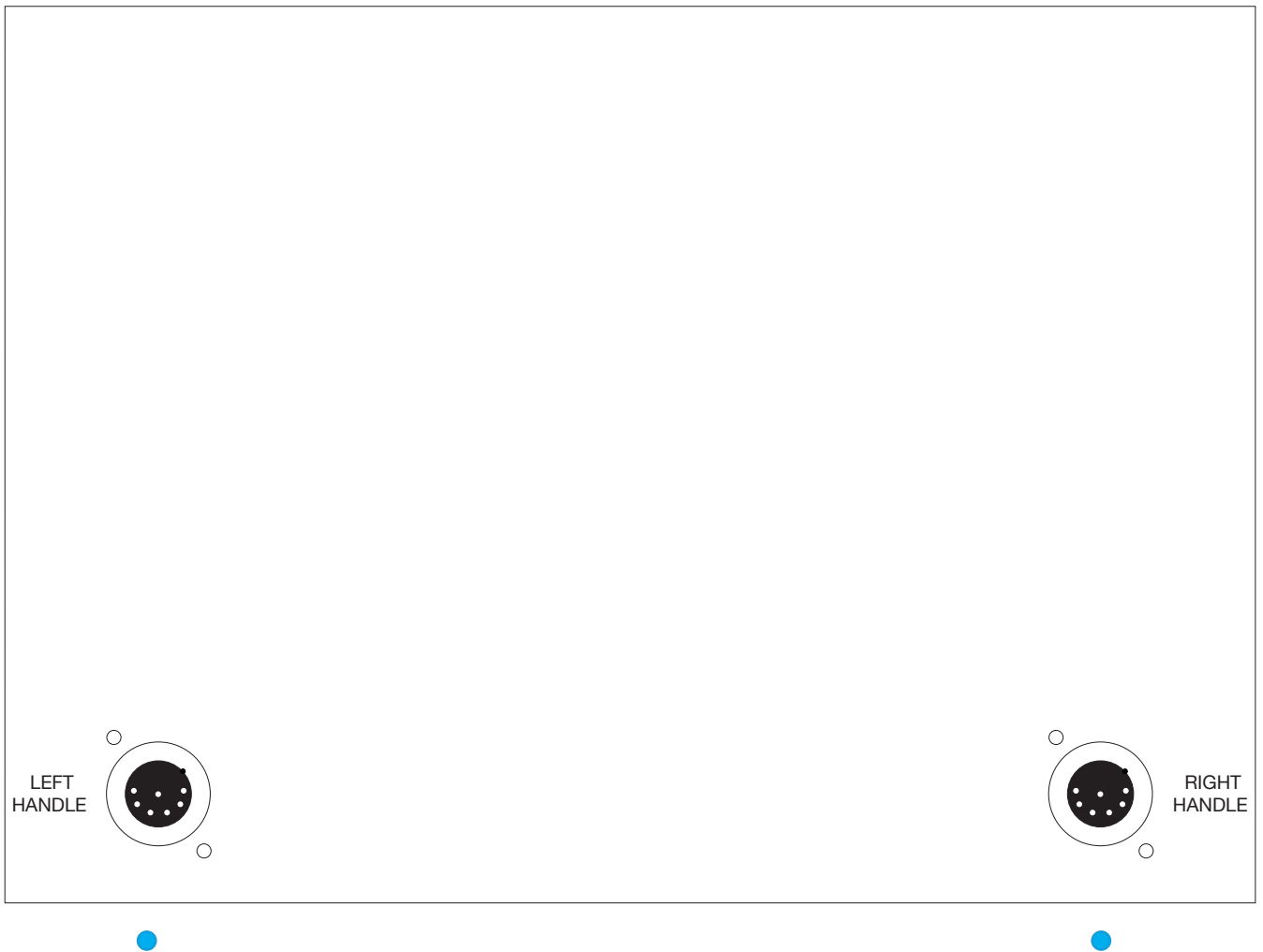

# System Hook Up

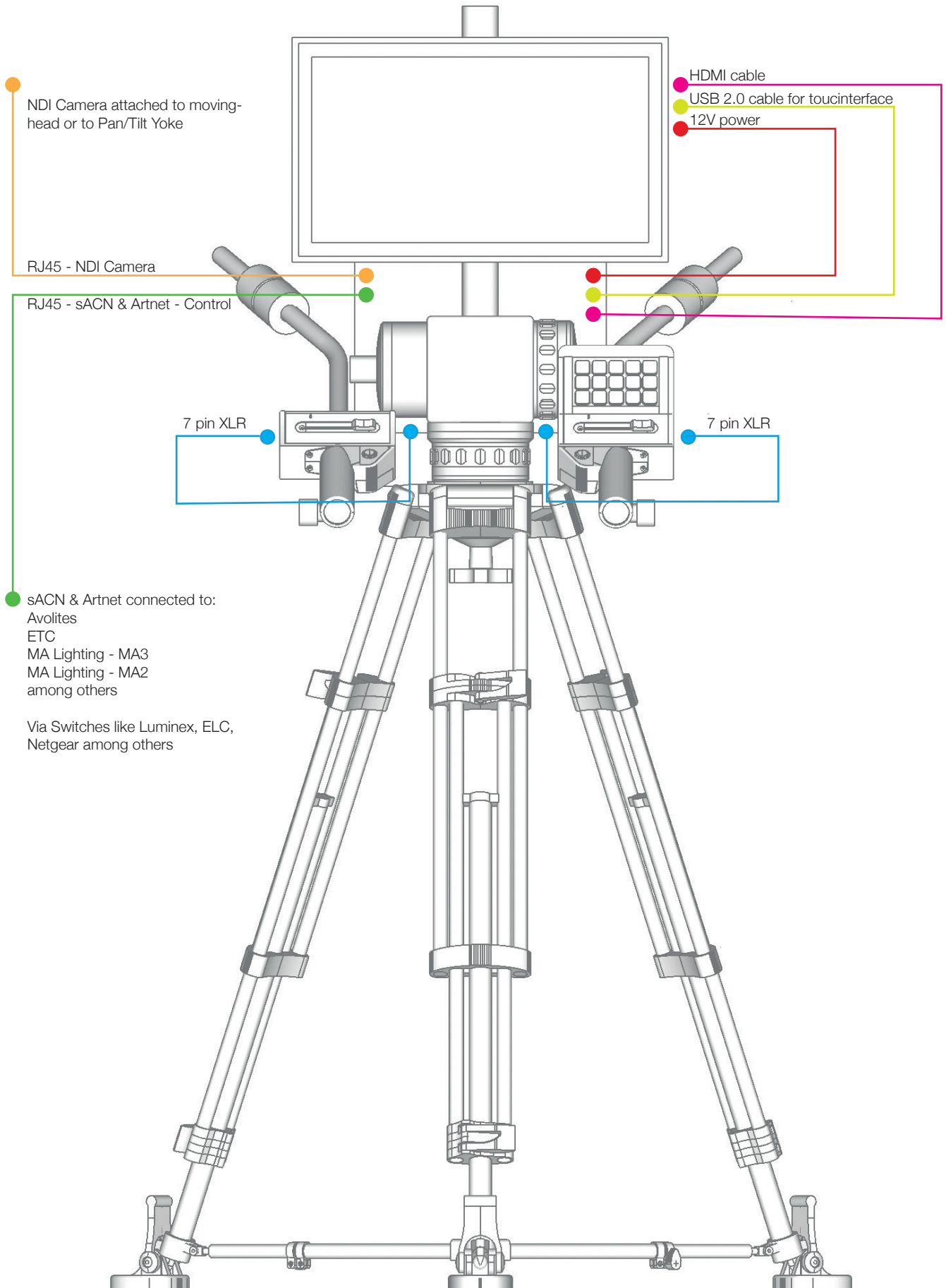

# Left Handle Bar

---

#1 - Connect the LEFT handle bar with the 7 pin XLR to the Macula Encoder Unit. The 7 pin XLR Neutric deliver power and signal to the handle bar.

The handlebar is digital and the setup of the item is softwarebased which, controlled intuitively via the touchscreen.

The function of the Physical interface can be changed in the software. Saving a showfile will keep all the changes.

#2 - default set to BLACK OUT, to obtain the black out the button has to have a fixed push, when releasing the the fixtures immediately kicks in.

#3 - MOTORFADER default set to DIMMER, it is possible to alter the function to control IRIS, CTO, ZOOM. This is done in the lower left corner of the touch screen.

#4 - LED indicators

LED Green symbols data flow, flashing data runs

LED YELLOW indicate that your finger is resting on the fader and will cancel activation of the motorfader, when the system sense that a finger is resting on the motorfader it assume that the spot operator want to to execute of the fade in of the action.

#5 - ROLE ENCODER default set to Z-axis compensation for slave fixtures. In future software releases the Encoder can be set to different purposes.

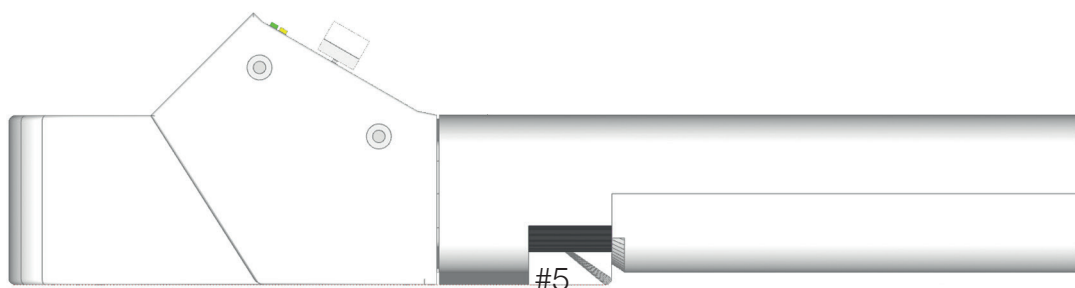
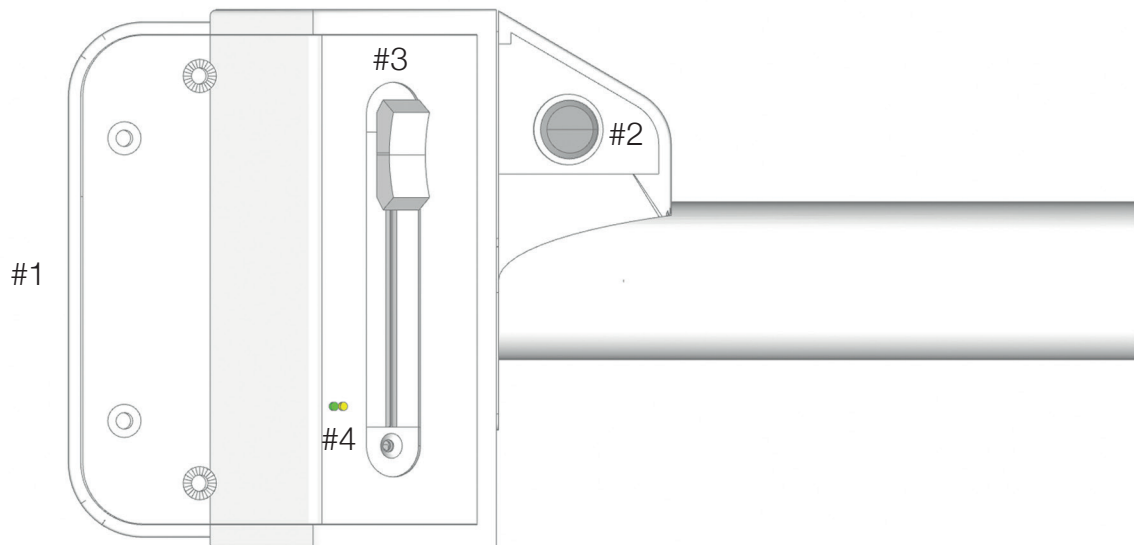

# Right Handle Bar

---

#1 - Connect the RIGHT handle bar with ● the 7 pin XLR to the Macula Encoder Unit. The 7 pin XLR Neutric deliver power and signal to the handle bar.

The handlebar is digital and the setup of the item is softwarebased which, controlled intuitively via the touchscreen.

The function of the Physical interface can be changed in the software. Saving a showfile will keep all the changes.

#2 - default set to FREEZE, when pushed it enables you to adjust the PAN and TILT function without moving any fixtures as long as the button is pushed, when releasing the button the PAN and TILT becomes active again.

#3 - MOTORFADER default set to IRIS, it is possible to alter the function to control DIMMER, CTO, ZOOM. This is done in the lower right corner of the touch screen.

#4 - LED indicators

LED Green symbols data flow, flashing data runs

LED YELLOW indicate that your finger is resting on the fader and will cancel activation of the motorfader, when the system sense that a finger is resting on the motorfader it assume that the spot operator want to to execute of the fade in of the action.

#5 - KEYPAD - 15 presets can be stored to the keypad, the presets are created in the software like it based on typical movinghead programming each preset can be programmed with a fade in time as well positioning of the followspots main and slave fixtures this secure that precise positioning under a blackout is possible, In future software releases added pages will be integrated to this feature.

#6 - ROLE ENCODER is not active in future software releases this encoder will enable control of different purpose.

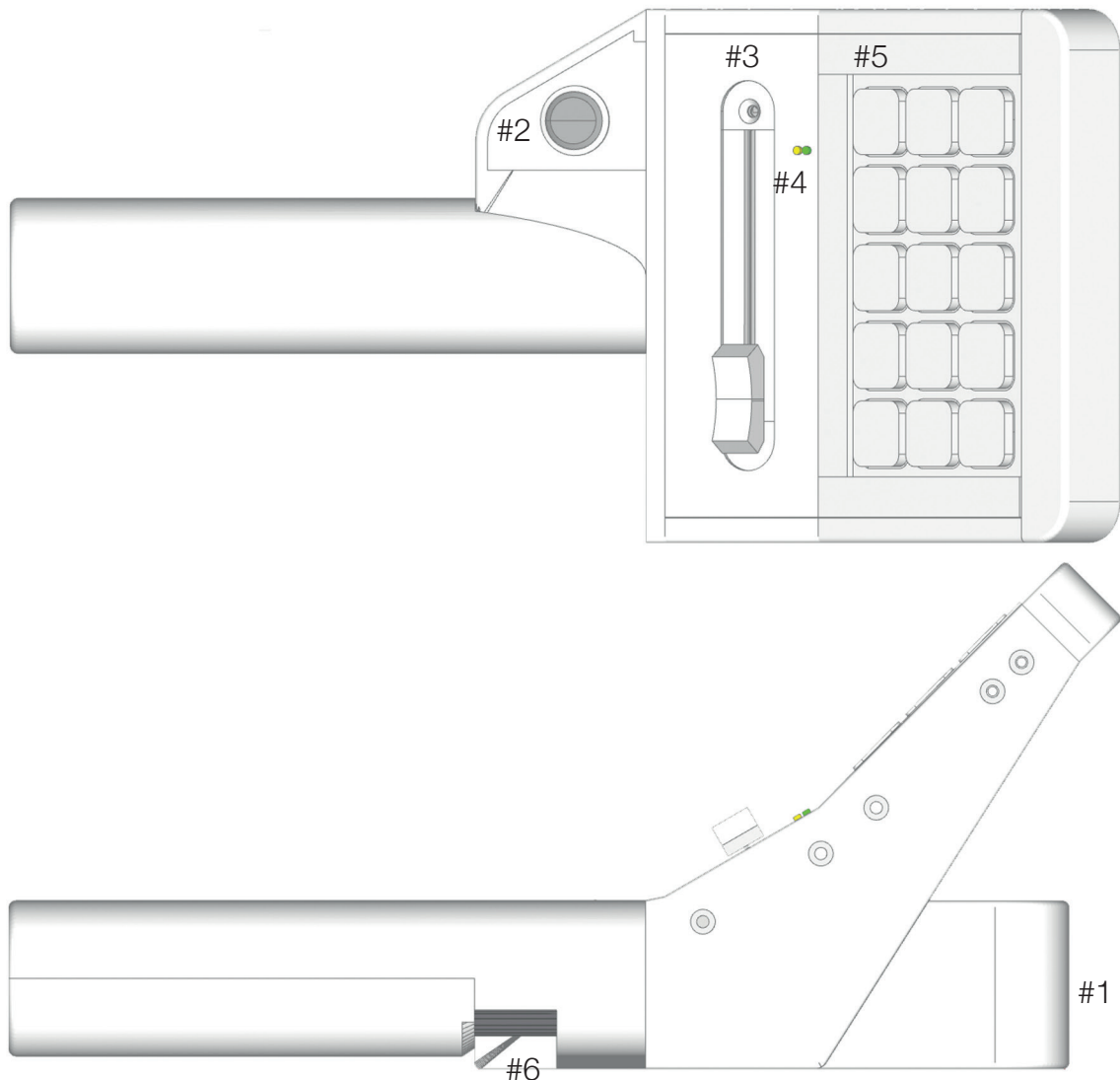

# System

Selecting the SYSTEM tab opens the folder of the system settings on the touch screen. this tab includes the following functions:

- SHOW FILE: First time you boot the system the list of shows appear empty  
Type your name of the show in the //NEW SHOW NAME...// push //SAVE AS//
- NETWORK ETH0: Type your IP adress in the range of DMX nodes in this Example: 192.168.10.1
- NETWORK ETH1: DHCP
- VIDEO SWITCH: Locked default at: 192.168.100.101  
This IP adress can be chanced via contacting your local Macula dealer.
- SAVE: Push //Save// everytime settings has been changed in the System, fixtures and camera folders. The Macula system do not have AUTO SAVE functions.
- LOAD: Push // Load// to load stored shows

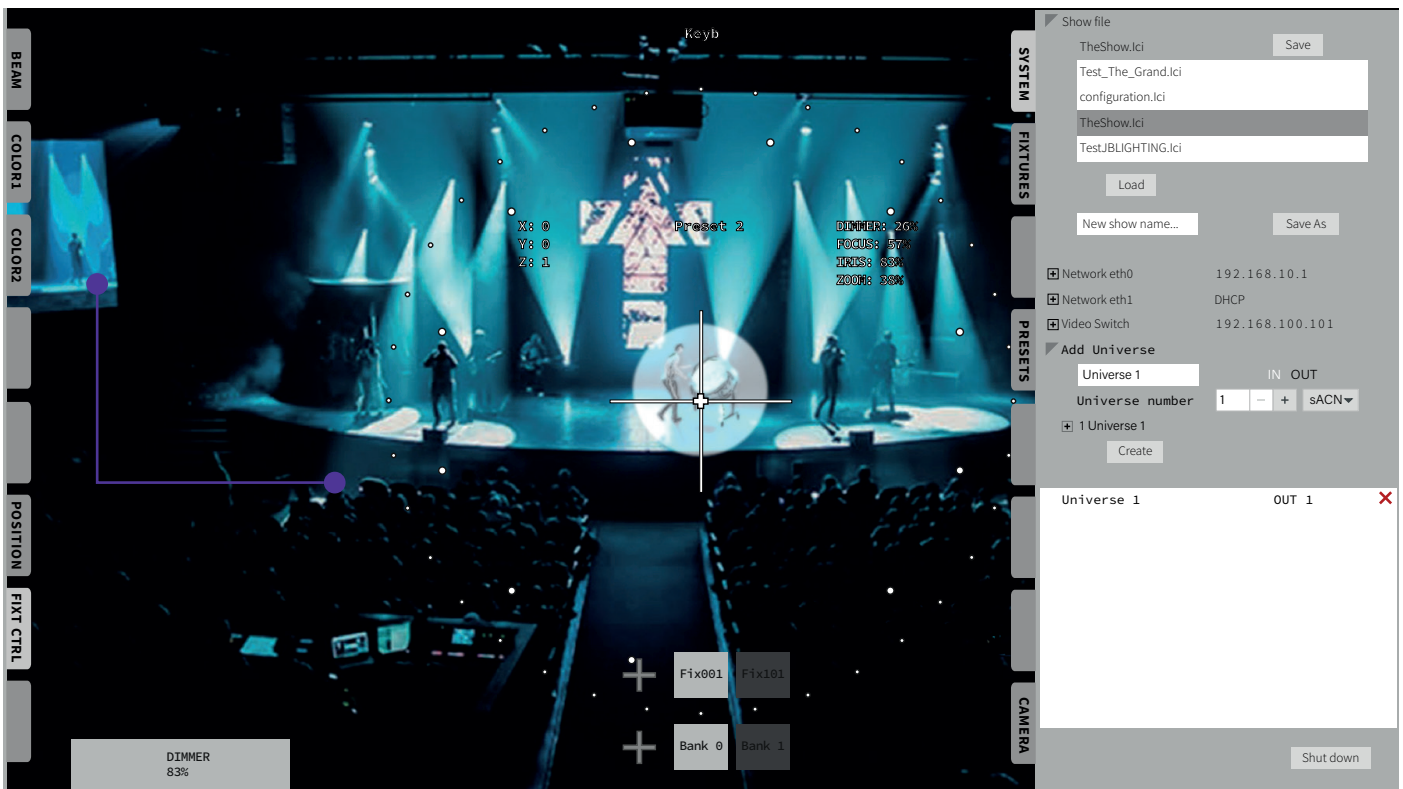

ADD UNIVERSE: Type your universe name, in this example: Universe 1  
Use the -/+ keys to adress the universe number this example: 1  
In the scroll bar select either Artnet or sACN, this exmple: sACN  
Select if the DMX universe shall point in or out in this example: OUT

CREATE: Push the //CREATE// key

The Universe are now appearing in the list below the create key in this list all universes are described with name function of in or out and which DMX universe i relates to.

SHUT DOWN: Push //SHUT DOWN// key and the Macula system will shutdown

This Symbol **X** are indicating that it is possible to delete the universe.



# Fixtures

Selecting the FIXTURES tab opens the folder of the fixture settings on the touch screen. this tab includes the following functions:

**ADD FIXTURE:** From the planning, type the identity name of the fixture you want to add in this example: Fix001

**SELECT PROFILE:** Choose from the library the correct fixture type in this example: VL VLZ Profile 16B default

**UNIVERSE:** Push the //+// key to expand the list of DMX universes, in this example: 1 universe 1

**DMX ADDRESS:** Type in adress for the given fixture in this example: 1

**PRIMARY:** The given fixture will become a primary if the camera is selected in the patching

Finalize all the transactions with push the key //Create and Patch//

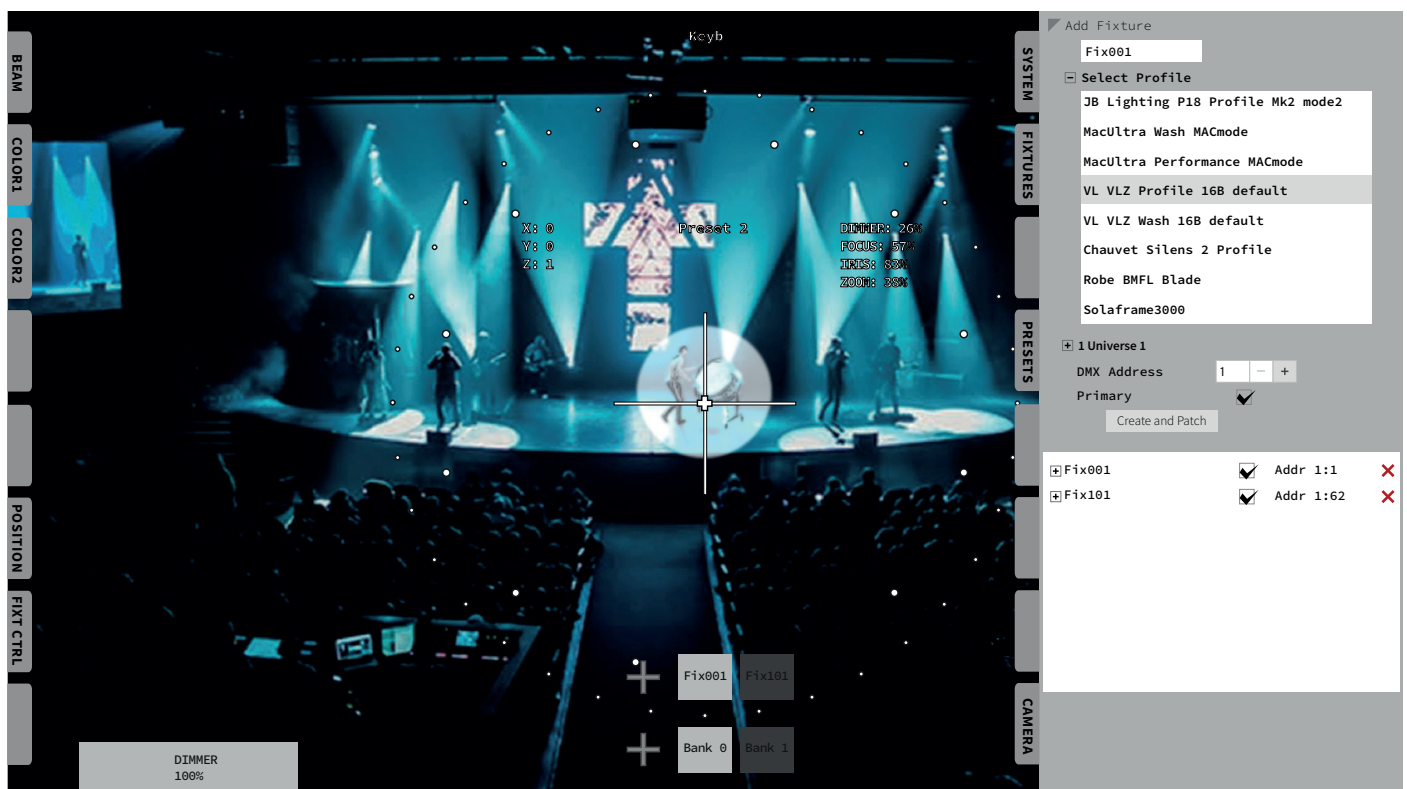

This Symbol **X** are indicating that it is possible to delete the fixture.

# Fixtures

Unfolding fixture information for the //Fix001// enables a more detailed list of what the fixture carry. in this Example:

Patch to: 1 Universe 1  
Camera: BIRDDOG-4281E (CAM)

If no camera are selected to the fixture the title //SELECT// will indicate the option of choosing a viewport as a device.

MULTI FIXTURE:            Unfold parameters belonging to Fix001

CHANNELS:                Unfold channels belonging to Fix001

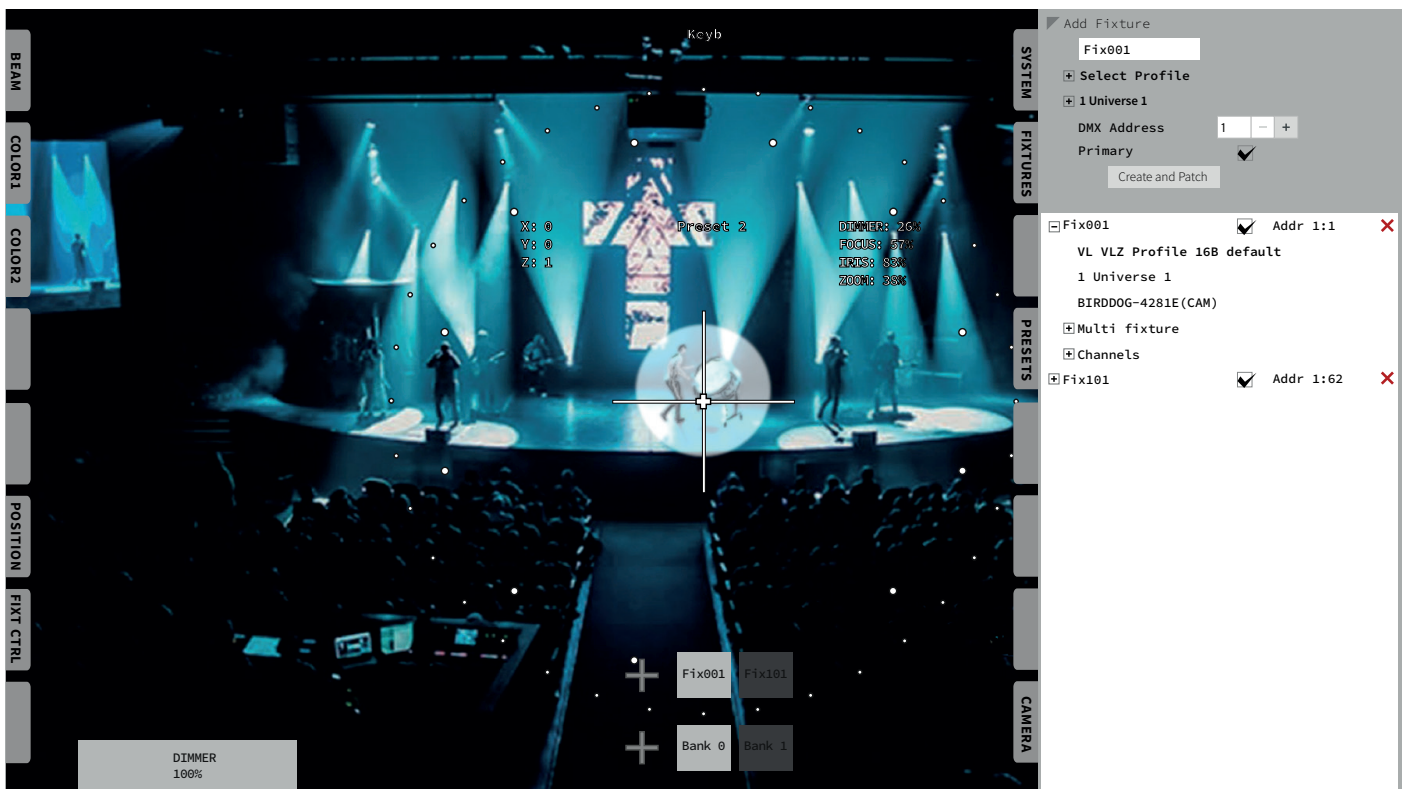

# Fixtures

Unfolding MULTI FIXTURE presents the option of placing the fixtures real physical position in the venue.

As mentioned in the distinction Macula as a default works from the primary fixture out. This is why it is of greatest importance that the measuring of fixtures are correct and perfectly related.

In this example we are placing our Primary Fixture //Fix001//:

- X = 0,00 This is always 0,00 due to we are measuring from this point to the slave fixtures (Metric)
- Y = 0,00 This is always 0,00 due to we are measuring from this point to the slave fixtures (Metric)
- Z = 10,00 This is set to 10,00 meters (Metric)
- PAN OFFSET Fine tuning the the precision with adding a small amount of a offset
- TILT OFFSET Fine tuning the the precision with adding a small amount of a offset

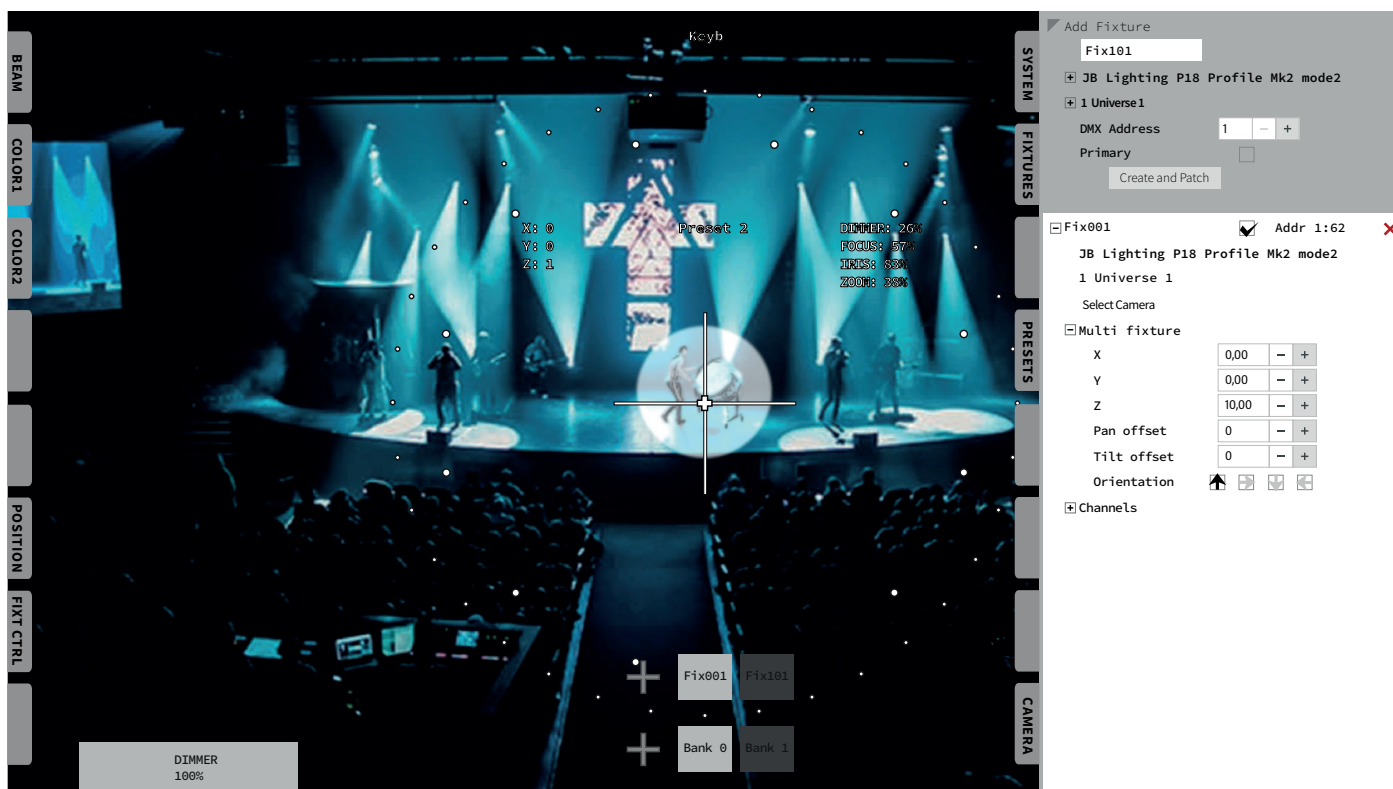

ORIENTATION

Describe in the ticker box which the fixture front is pointing



# Fixtures

Unfolding CHANNELS presents the option to first of all have an overview of the given fixtures channels.

MIX: Tik this box if you wish to enabling sharing between the LD and the Operators data

ACT, ACTIVE: Tik this box if you wish to have the control of the given channel from the Macula System

INV, INVERT: Tik this box if you want to have the channel working opposite

LOCK: Tik this box if you wish to lock this channel

The 2 columns of numbers defines the default DMX value programmed to the FIXTURE PERSONALITY in the library.

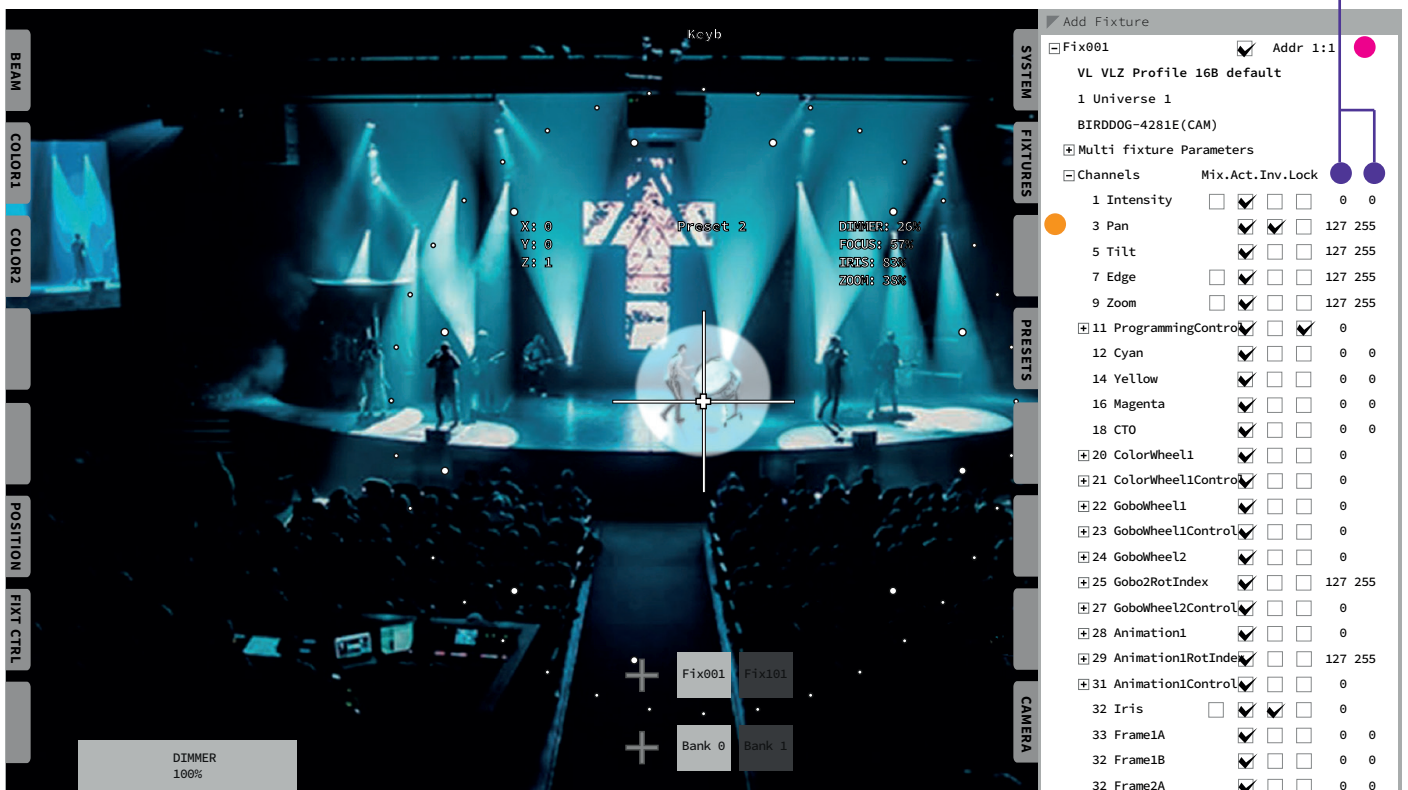

**CHANGE PATCH:** Push //Addr// area in this example //Fix001// This opens a dialog box where you can change the DMX address and Universe number

**ALTERNATE ROUTE:** Push //pan// area this opens a dialog box where it is possible to change the channel number for this specific feature.

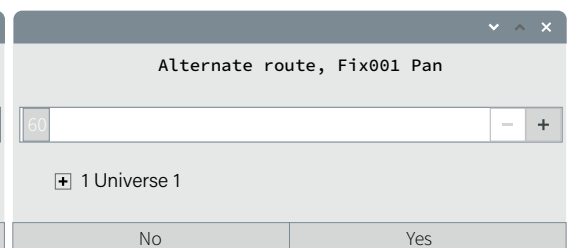
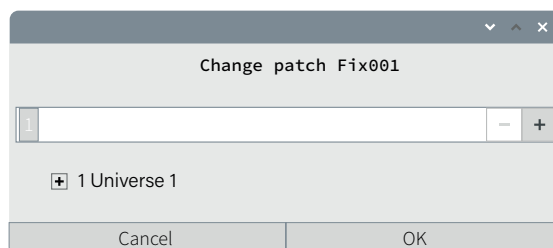

# Presets

Selecting the PRESETS tab opens the folder of the preset functions on the touch screen.

Generally a preset stores all the adjustments done to fixtures. The Macula system are based on banks of fixtures. A bank holds a group of fixtures. push //BANK// key push //Fix001// key now it is possible to change the settings for this specific fixture. In this example //Fix001// has been modified for the following features Dimmer, Zoom, Focus, Iris and CTO. //Fix101// has been modified Position, Dimmer, Zoom, Focus, Iris and Color.

Push //Preset name// area add the intended name in this example: Preset 3

Push //+/+// keys to add a fade time, in this example time = 0,0

Push either //Assign Key// now the KEYPAD starts flashing buttons, bump the key to place the preset.

or

Push //Add Preset// and the preset will appear in the preset list

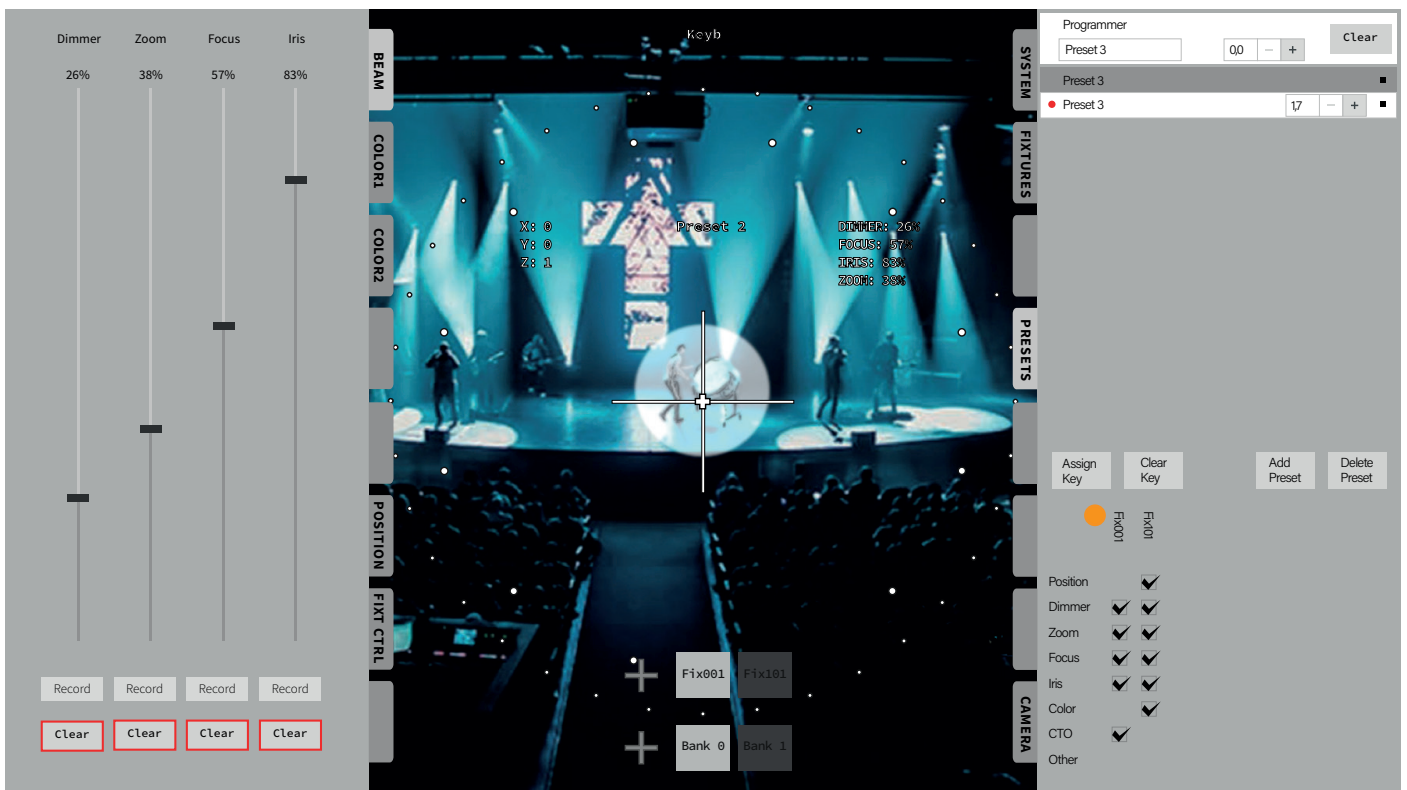

## ASSIGN KEY

Push //Assign Key// push the example //Preset 3// the keypad now starts flashing place the preset to the right position on the keypad.

## CLEAR KEY

Push //Clear Key// to clear any undesired preset on the keypad. The preset are still existing in the preset list.

## DELETE PRESET

Push //Delete Preset// push example //Preset 3// this will delete the preset in total.

To update a preset it is important to load/call the correct preset to update, in this example //Preset 3//. Then push the fixture you want to change levels to then push //Assign Key// or //Add Preset// push //preset 3//. A pop up window opens a dialog asking do you want to store and merge.

- Before storing or updating a preset it is possible to deactivate some of the functions removing the tick in the list.

It is possible to rename presets and add fade times.



# Camera

Selecting the CAMERA tab opens the folder of the camera functions on the touch screen.

- ZOOM: This fader controls the zoom from wide to tele fader
- FOCUS: This fader controls the area of focus
- AUTO FOCUS: Switch on or off auto focus function
- ONE PUSH AF: Zoom in to the talent push //One push AF// the camera generate sharpness instantly.
- EXPOSURE: Controls the aperture of the camera, controlling how bright or dark the picture is
- AUTO EXPOSURE: Controls automatically the exposure against the talent and invironment.

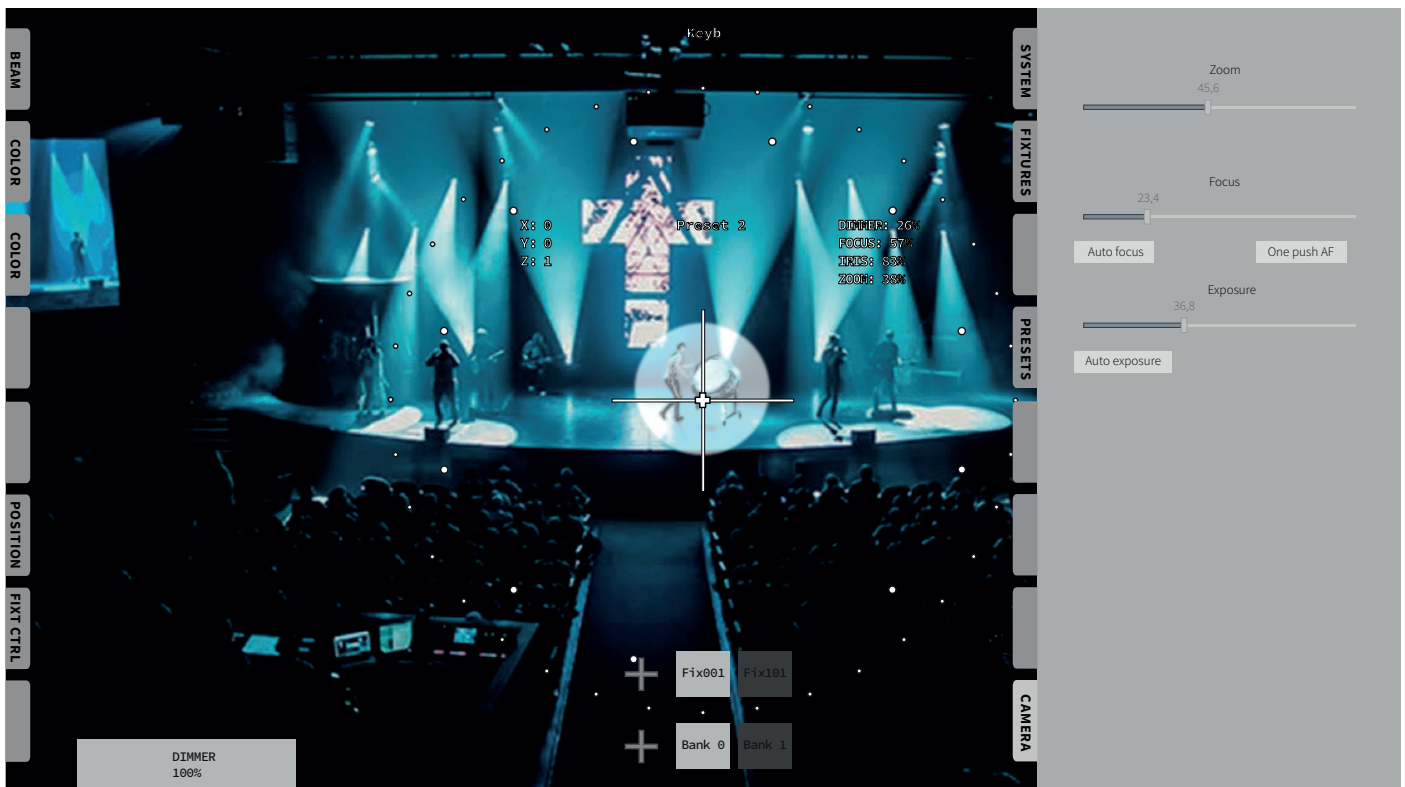

# Clean View - Operator

The Macula System creates an overlay with the GUI interface on the touchscreen. This give access to all the functions in the system.

LEFT tabs are oriented towards the operator and the control of the fixtures.

RIGHT tabs are oriented towards System Technical Department. among the right tab are MEMORY in this tab you will store all preset to be executed via the KEYPAD.

- Z-AXE - describes the offset to slave fixtures
- PAN - indicate the precise number of the position in bits
- TILT - indicate the precise number of the position in bits
- DIMMER - shows the level percentage of the PRIMARY FIXTURE
- FOCUS - shows the focus position of the PRIMARY FIXTURE
- IRIS - shows the iris position of the PRIMARY FIXTURE
- ZOOM - shows the zoom position of the PRIMARY FIXTURE

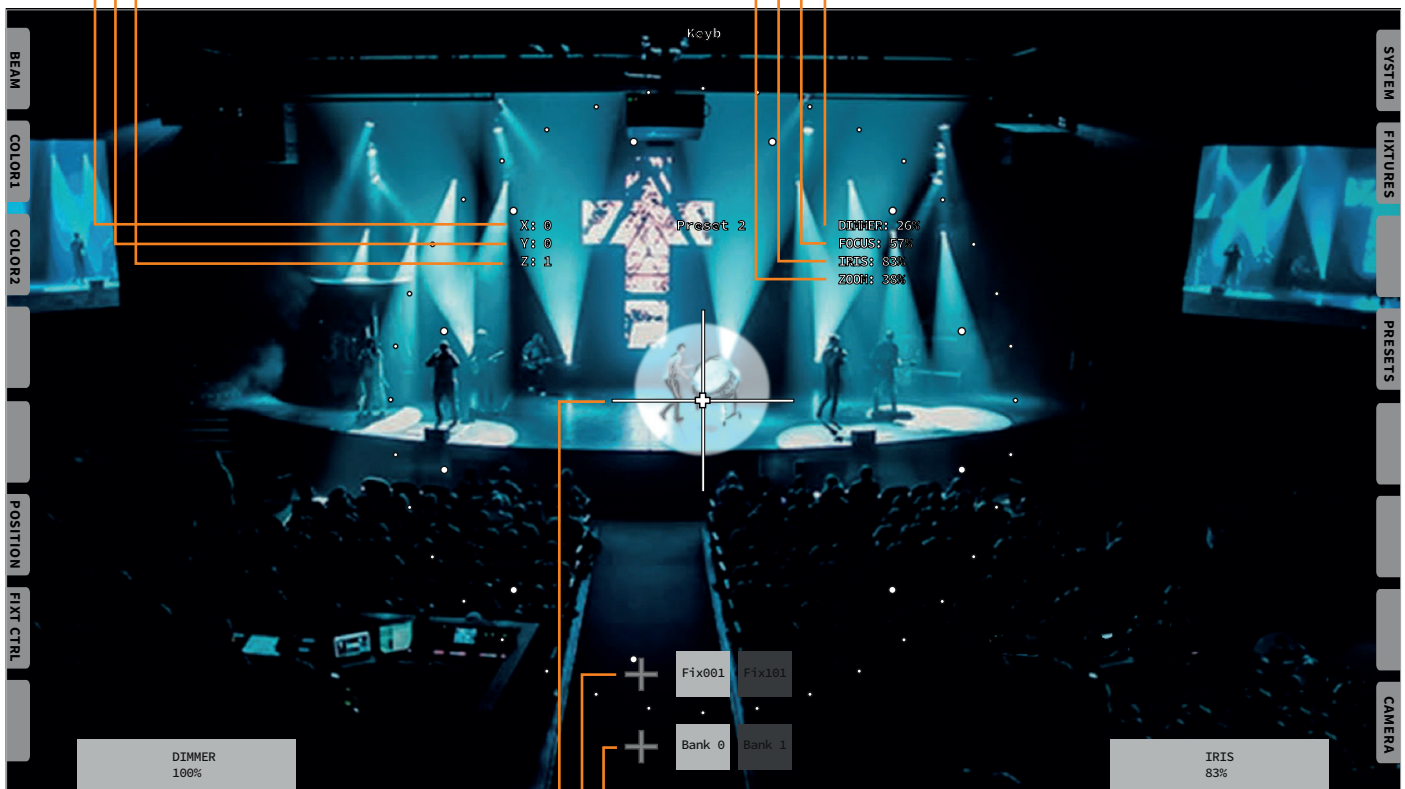

TARGET it is possible to physically move the target indicator to an offset position to serve better alignment to the actually position of the camera. The cross indicate center of beam, the small "fader" indicates how far from 50/50 pan and tilt are positioned, the circle with small dot pattern reflects how large the attack of the iris is, the circle with larger dotted pattern describes the zoom.

BANK - holds on to a group of assigned fixtures the Macula System can operate numbers of banks, when a bank is activated the Macula System takes over these fixtures. when switching to another bank the fixtures not included in the bank will be released over a default fade time of 5 seconds back to the complete system

FIXTURE - show the assigned fixtures to the different banks

# Beam Settings

Selecting the Beam tab opens the folder of the beam settings on the touch screen. this tab includes the following function faders:

DIMMER / ZOOM / FOCUS / IRIS

Before modifying any of the faders, it is crucial to choose the BANK. All the fixture belonging to a bank now becomes active in the programmer. This means that all values of the banks fixtures will be stored when you save the preset. To individually change the settings per lamp you have to choose the fixture.



In this example we use //BANK 0// and //Fix001//

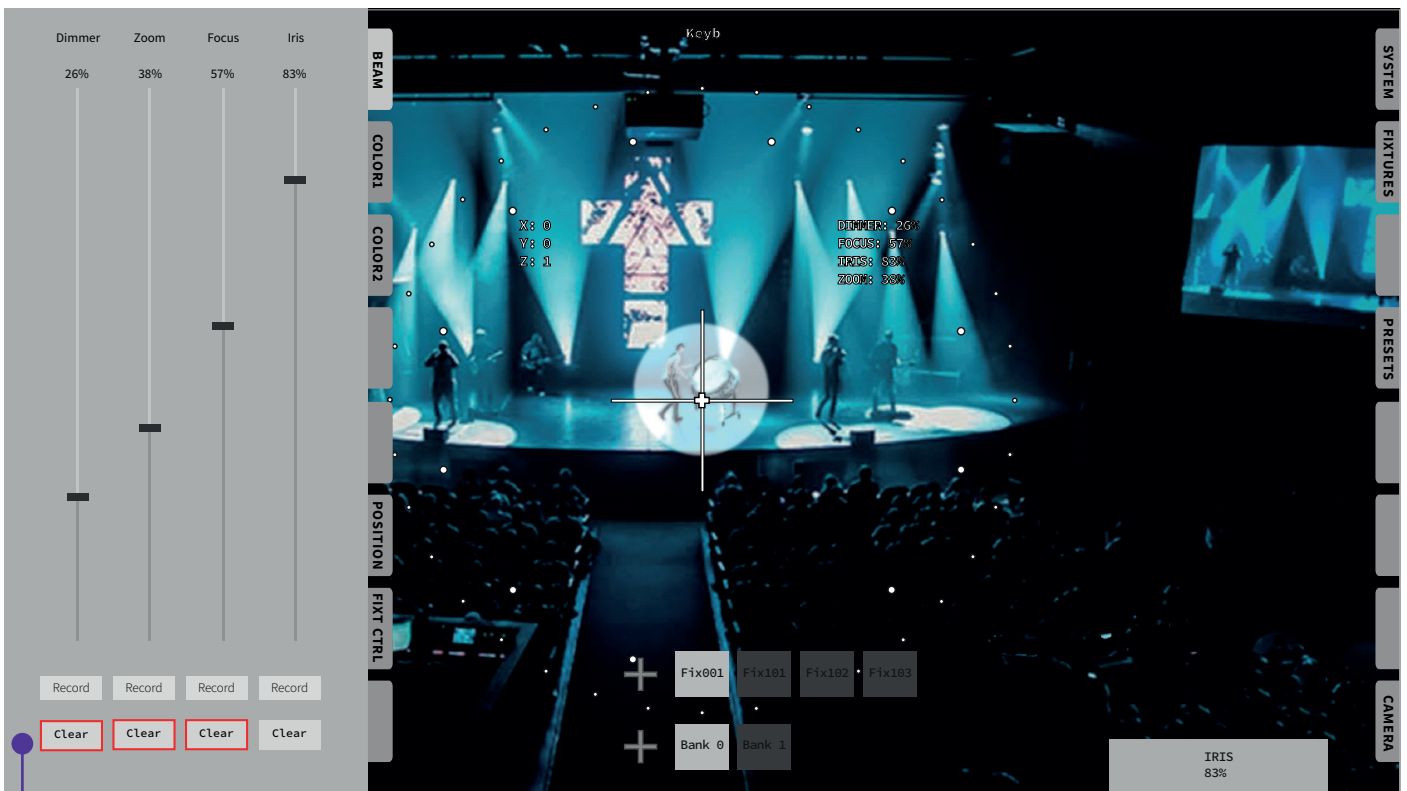

Now it is possible to add the the different levels of Dimmer, Zoom, Focus and Iris to the individual //Fix001// the data is kept active in the programmer and it is possible to move to the next fixture of choice.

When changing the values on the fader the //CLEAR// button are outlined with red indicator that means active. It is possible to clear the modification. When clearing the modification of the fixture parameter it will become passiv in the programmer.

**IMPORTANT** If you wish to be able to store a value for the selected fixture you need to move the fader again to the intended value

After altering //Fix001// you deactivate the fixture by pressing the //Fix001// key on the touch screen and now you activate the next fixture example //Fix101//

When all changes have been done you are ready to store it as a preset.



# Color1 Settings

Selecting the Color1 tab opens the folder of the CMY/RGB settings on the touch screen. this tab includes the following function faders:

Subtractive CYAN/MAGENTA/YELLOW or Additive RED/GREEN/BLUE and a COLORPICKER

Before modifying any of the faders, it is crucial to choose the BANK. All the fixture belonging to a bank now becomes active in the programmer. This means that all values of the banks fixtures will be stored when you save the preset. To individually change the settings per lamp you have to choose the fixture (see beam settings).

All fixtures from the selected bank are indicated in the colorpicker with a square. In this example 2 squares are present which indicate that there are 2 fixtures in the bank. Also a ghosting fader indicator are present on the cyan, magenta and yellow fader.

● Selecting //Fix001// marks the fixture indication in the color picker with a BOLD outline.

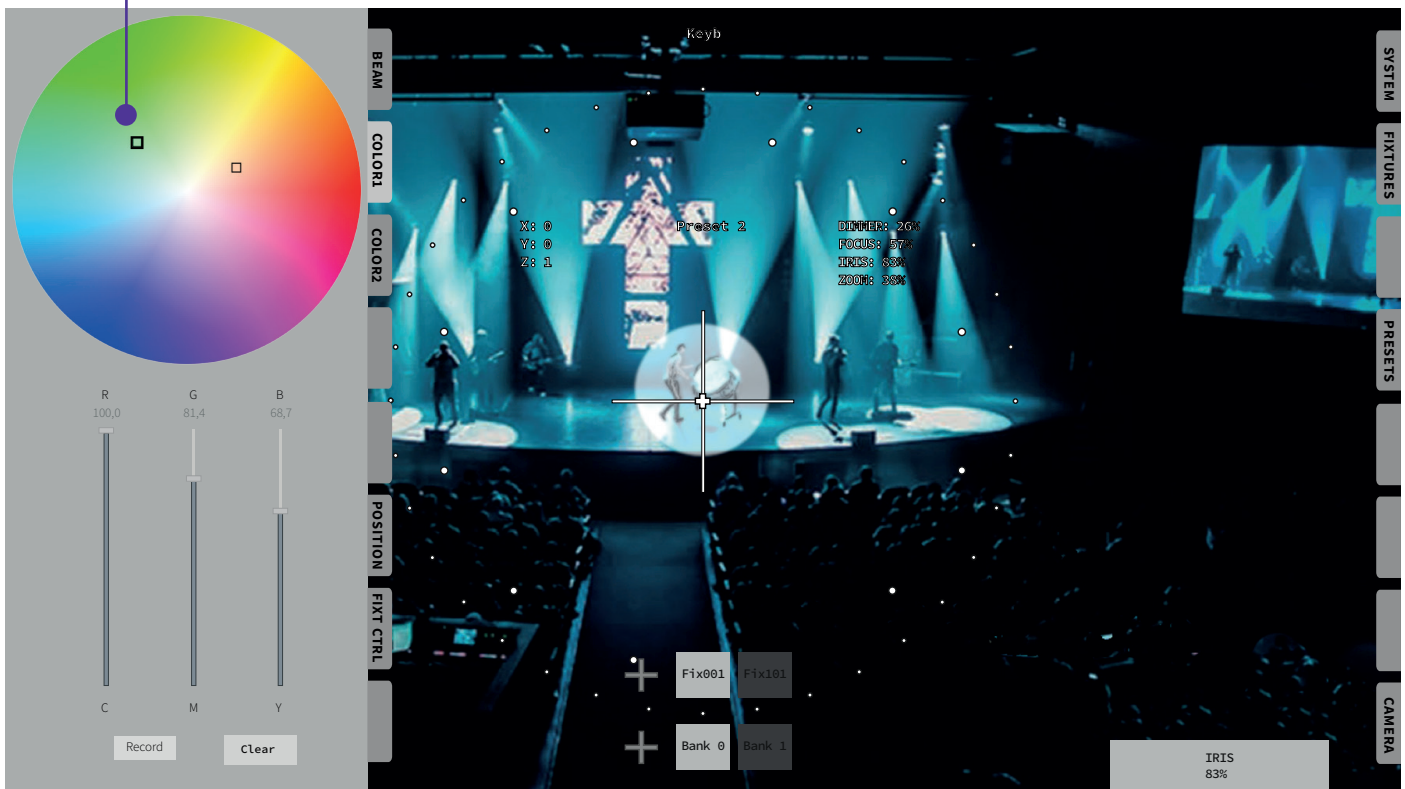

In this example we use //BANK 0// and //Fix001//

Now it is possible to add the the different levels of cyan, magenta and yellow to the individual //Fix001// the data is kept active in the programmer and it is possible to move to the next fixture of choice.

When changing the values on the fader the //CLEAR// button are outlined with red indicator that means active. It is possible to clear the modification. When clearing the modification of the fixture parameter it will become passive in the programmer.

**IMPORTANT** If you wish to to be able to store a value for the selected fixture you need to move the fader again to the intended value

After altering //Fix001// you deactivate the fixture by pressing the //Fix001// key on the touch screen and now you activate the next fixture example //Fix101//

When all changes have been done you are ready to store it as a preset.

# Color2 Settings

Selecting the Color2 tab opens the folder of the CTC settings on the touch screen. this tab includes the following function fader:

CTO - COLOR CORRECTION

Before modifying the fader,

it is crucial to choose the BANK. All the fixture belonging to a bank now becomes active in the programmer. This means that all values of the banks fixtures will be stored when you save the preset.

To individually change the settings per lamp you have to choose the fixture (see beam settings).

In this example we use //BANK 0// and //Fix001//

Now it is possible to add the the different level color correction on the individual //Fix001// the data is kept active in the programmer and it is possible to move to the next fixture of choice.

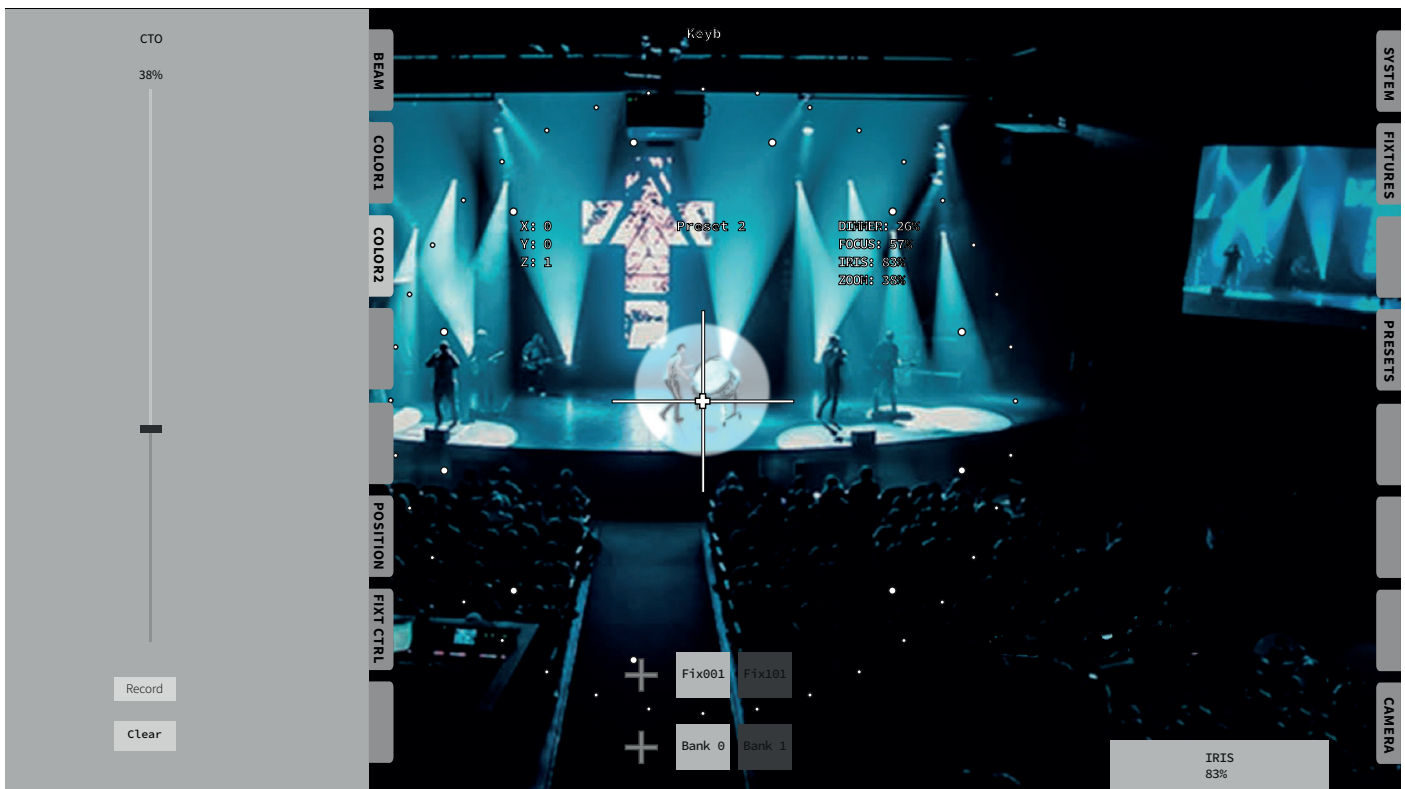

When changing the values on the fader the //CLEAR// button are outlined with red indicator that means active. It is possible to clear the modification. When clearing the modification of the fixture parameter it will become passive in the programmer.

**IMPORTANT** If you wish to be able to store a value for the selected fixture you need to move the fader again to the intended value

After altering //Fix001// you deactivate the fixture by pressing the //Fix001// key on the touch screen and now you activate the next fixture example //Fix101//

When all changes have been done you are ready to store it as a preset.



# Position Settings

Selecting the Position tab opens the folder of the POSITION settings on the touch screen. this tab includes the following function fader:

## Z-AXE

Before modifying the fader,

it is crucial to choose the BANK. All the fixture belonging to a bank now becomes active in the programmer. This means that all values of the banks fixtures will be stored when you save the preset.

To individually change the settings per lamp you have to choose the fixture (see beam settings).

In this example we use //BANK 0// and //Fix101//

Now it is possible to fine tune Z-AXE on the individual //Fix101// the data is kept active in the programmer and it is possible to move to the next fixture of choice.

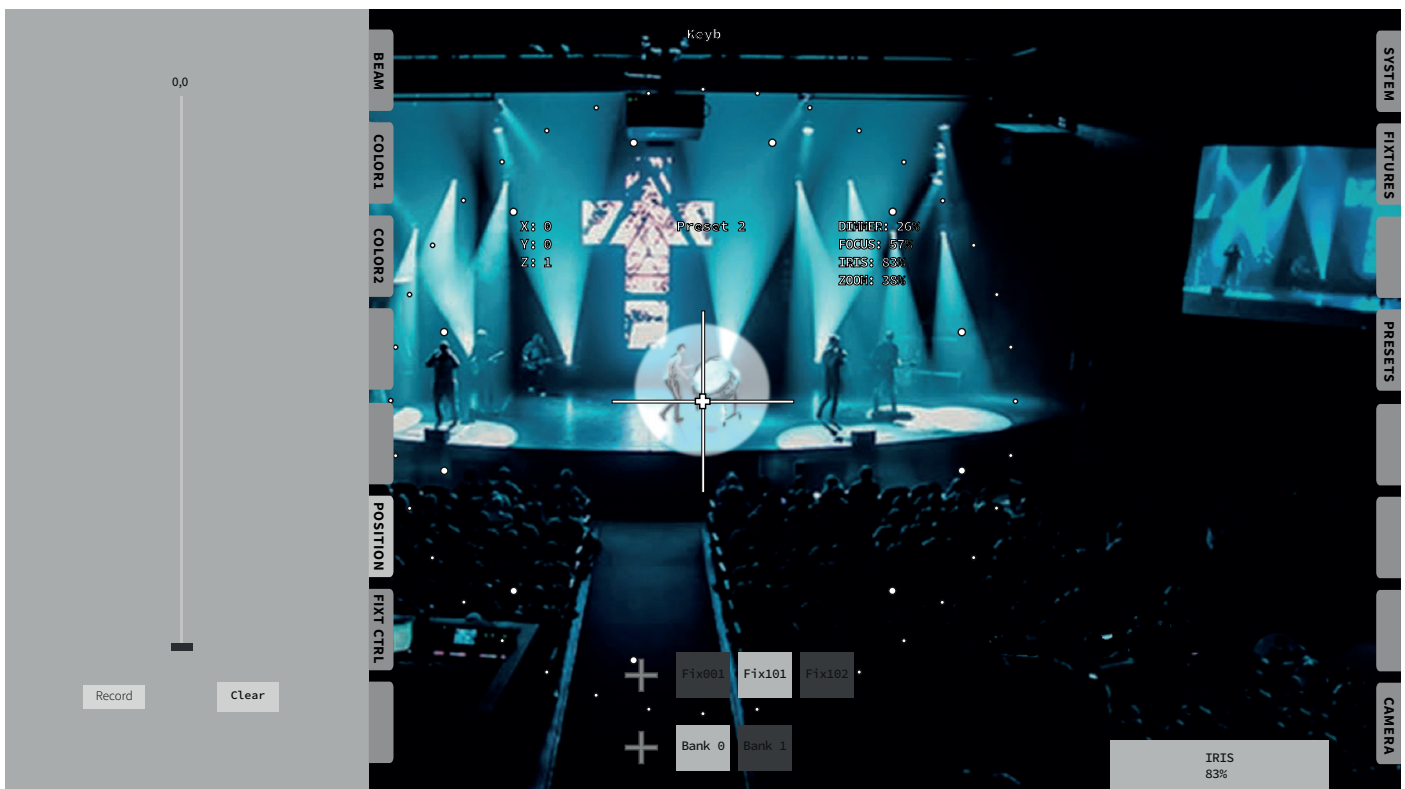

When changing the values on the fader the //CLEAR// button are outlined with red indicator that means active. It is possible to clear the modification. When clearing the modification of the fixture parameter it will become passive in the programmer.

**IMPORTANT** If you wish to be able to store a value for the selected fixture you need to move the fader again to the intended value

After altering //Fix001// you deactivate the fixture by pressing the //Fix101// key on the touch screen and now you activate the next fixture example //Fix102//. You never change the Z value for the Primary Fixture due to it is attached to the Operator.

When all changes have been done you are ready to store it as a preset.

At present this are meant for storing a predetermine position of a starting point to the KEYPAD where precision is needed at a swift.

In future releases this tab will develop the strength of flexibility.

# Fixture Control Settings

Selecting the Position tab opens the folder of the FIXT CTRL settings on the touch screen. this tab includes the following functions for the primary lamp mainly and for the slave fixtures.

- PAN: Adjust the reaction sensibility of the Fluid Head
- TILT: Adjust the reaction sensibility of the Fluid Head
- Z: Adjust the reaction sensibility of the Roll Encoder
- Left Fader: Invert fader direction of the motorized fader in left handle bar
- Right Fader: Invert fader direction of the motorized fader in right handle bar
- Invert: PAN/TILT/Z give the option to opposite the direction of the movement

The screenshot shows the Macula remote control interface. On the left, there are control panels for PAN, TILT, Z, Left Fader, Right Fader, Auto Dimmer, Auto Iris, Lamp On, Lamp Off, and Fixture Reset. The main area displays a stage view with a central camera view and various data points like X: 0, Y: 0, Z: 1, Preset 2, DIMMER: 26%, FOCUS: 67%, IRIS: 83%, and ZOOM: 35%. The interface is divided into sections: BEAM, COLOR1, COLOR2, POSITION, FIXT CTRL, and CAMERA.

- Auto Dimmer: This Feature is a unique Macula algorithm aim for broadcasting. The function creates a dynamical relationship between the Primary fixture and slave fixture. The Macula system will automatically increase the dimmer level as the talent walks closer to the Primary Fixture and dim the slave fixture as talent move closer to the slave. this ensures that the exposure seen thru a camera always will present the same expression.
- Auto Iris: This Feature is a unique Macula algorithm aim for broadcasting and Theaters. The function creates a dynamical relationship between the Primary fixture and slave fixture. The Macula system will automatically increase or decrease the Iris of the slave fixture which will narrow the "cone" to have a perfect fit according to the distance of the talent.
- Lamp On: Choose the fixtures to //LAMP ON//
- Lamp Off: Choose the fixtures to //LAMP OFF//
- Fixture Reset: Choose the fixtures to //RESET//



# Trouble Shooting

The System don't start

Make sure that power is connected to the external PSU.  
Make sure that the external PSU is connected to Macula CPU.

Data don't flow from handle bars

Are 7 pin XLR connected probably, make sure that the Neutric Plug are correctly placed in the Neutric chassis in the REAR BOX. Ensure that all the pins are in a good condition.

No Camera NDI signal

Make sure that the right handle bar is position to the right I/O port so data flows to the right feature.

Check if the camera gets Power and signal.

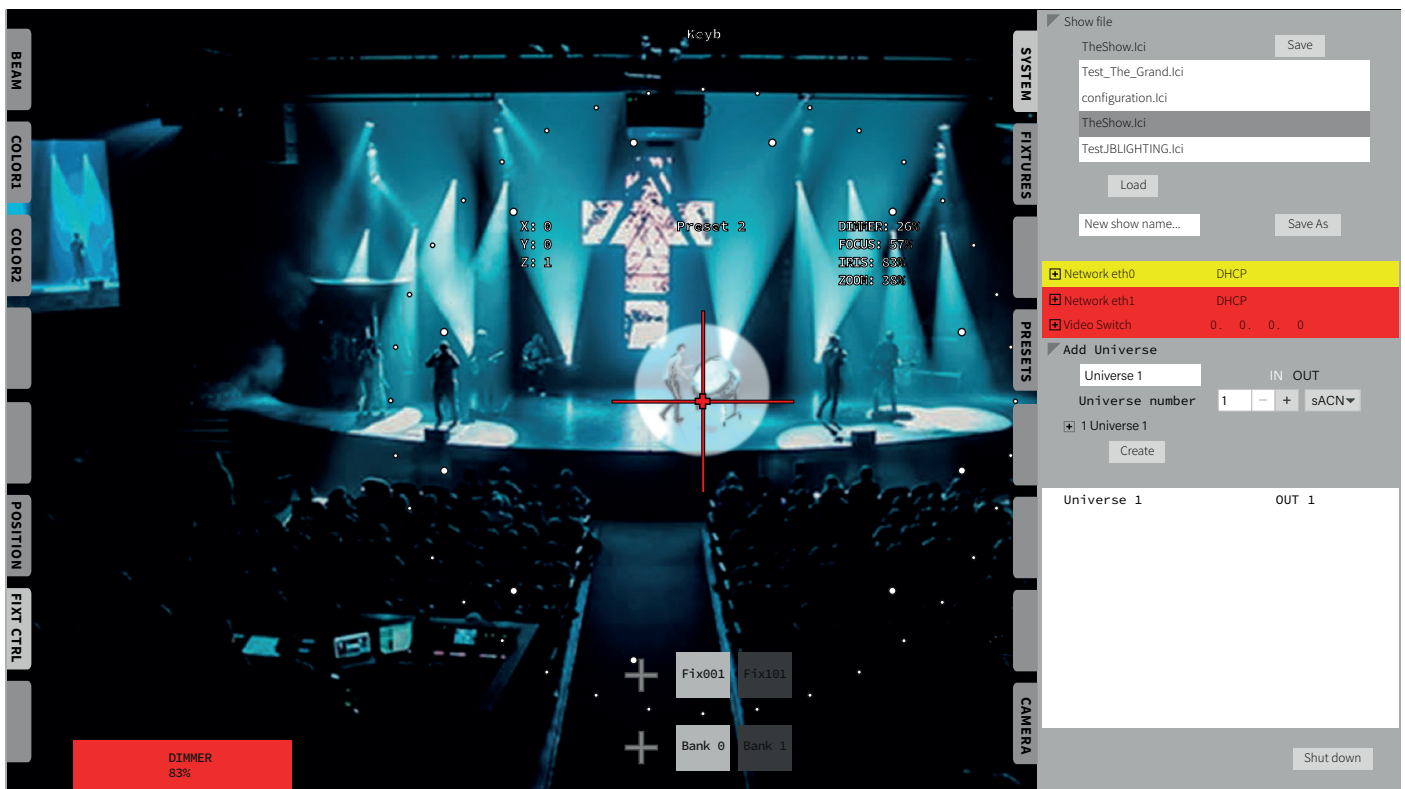

Software Color Messages

Red color means = No connection  
Yellow color means = Connection but no response back  
No color means = Connection

Fader indication on Screen are RED

The no connection from the handle bars to the REAR BOX, check the cables.



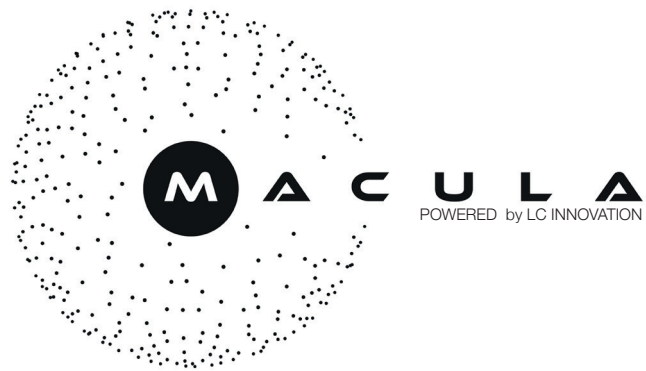

[www.macula.systems](http://www.macula.systems)

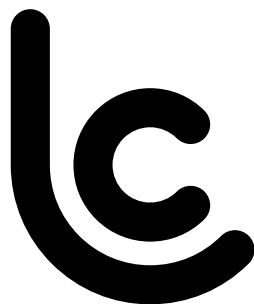

I N N O V A T I O N